

BOMBAS ALFA LAVAL

TIPO 11 Ø 40 - Ø 53 - Ø 60

Cierres mecánicos para Bombas ALC Serie D y ALP (sin carcasa de lavado)

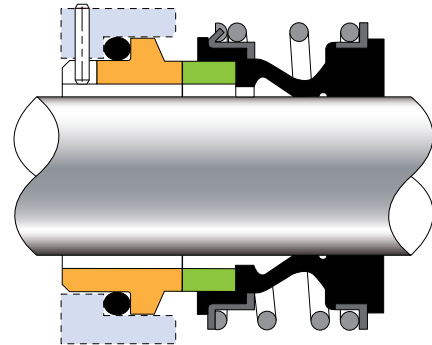

TIPO 82 Ø 53

Cierres mecánicos para Bombas CM, EM, FM, GM, LKH, MR & ALC (con carcasas de lavado, Serie F)

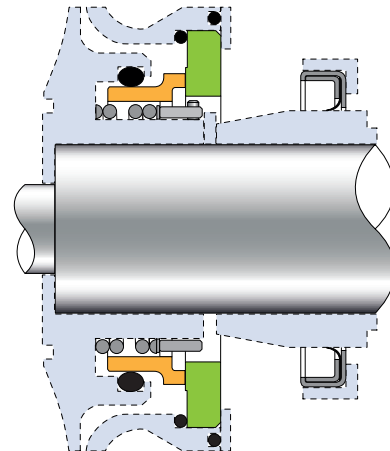

TIPO 67 Ø 22

Cierres mecánicos para Bombas CM1A, CM1B, CM1C, CM1D, EM1C, EM1D

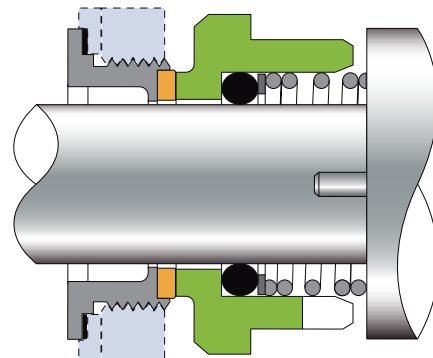

BOMBAS ALFA LAVAL

TIPO 68 Ø 32

Cierres mecánicos para Bombas tipo LKH5 a LKH60

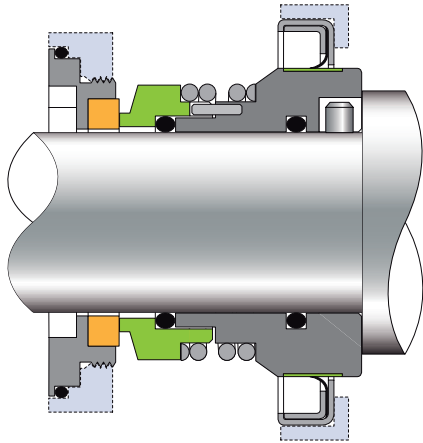

TIPO 69 Ø 22

Cierres mecánicos para Bombas tipo FMO, FMOS, FM1A, FM1AE, FM2A, FM3A, FM4A

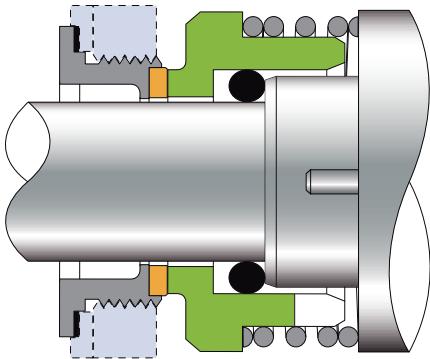

TIPO 70 Ø 27

Cierres mecánicos para Bombas tipo MR185A a MR200A

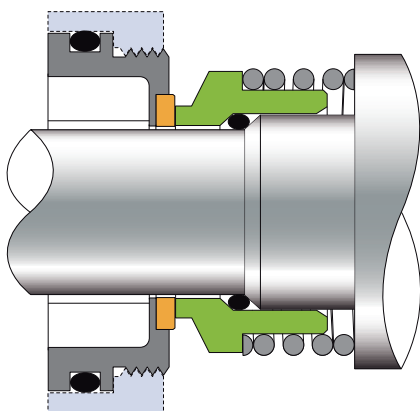

BOMBAS ALFA LAVAL

TIPO 71+78 $\varnothing 5/8'' - \varnothing 1 3/16'' - \varnothing 1 3/8'' - \varnothing 2'' - \varnothing 3''$

Cierres mecánicos para Bombas Lobulares tipo IBEX MOG 600, 1000, 2000, 3000 (SSP, I2, M2)

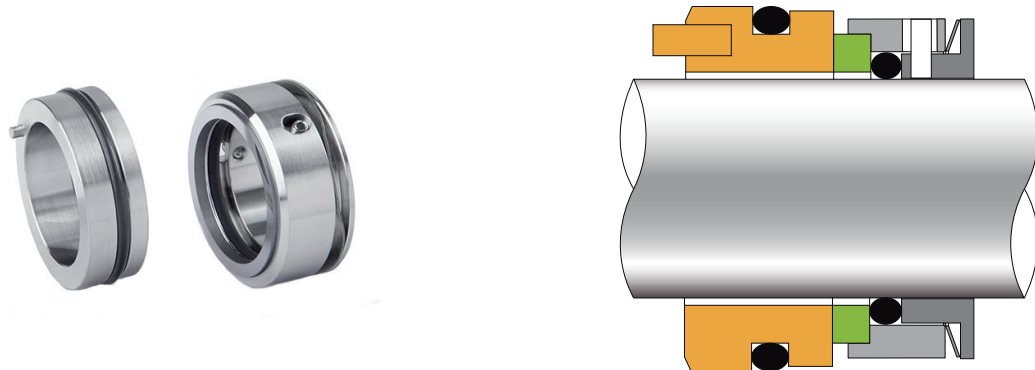

TIPO 71+78 $\varnothing 30 - \varnothing 35 - \varnothing 50 - \varnothing 70 - \varnothing 80$

Cierres mecánicos para Bombas Lobulares LKPL, NMOG, SRU, SSP y SR.

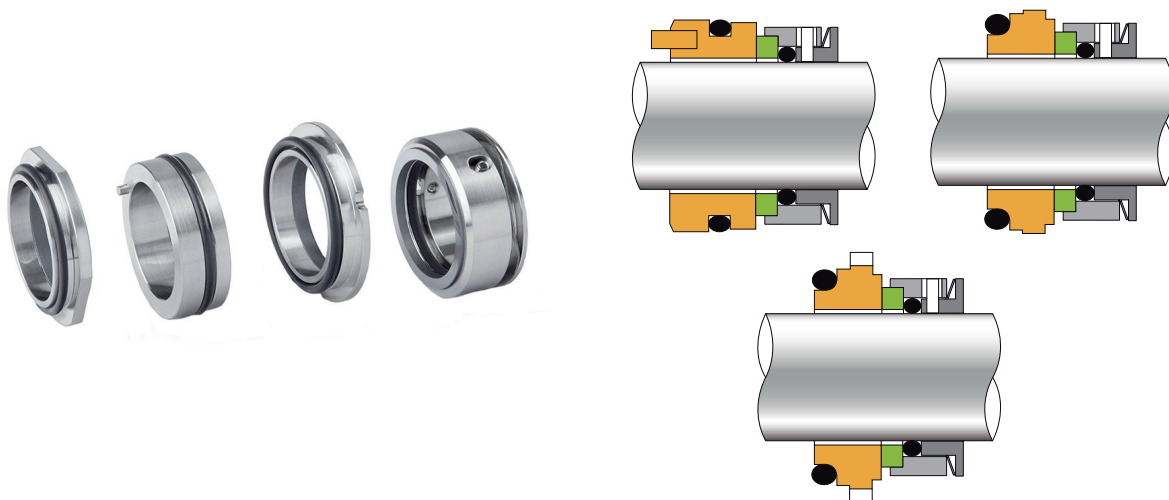

TIPO 74 $\varnothing 1 1/2'' - \varnothing 2''$

Cierres mecánicos tipo FLUSHINGLE para Bombas tipo CONTHERM. Camisa Inox/Silicio

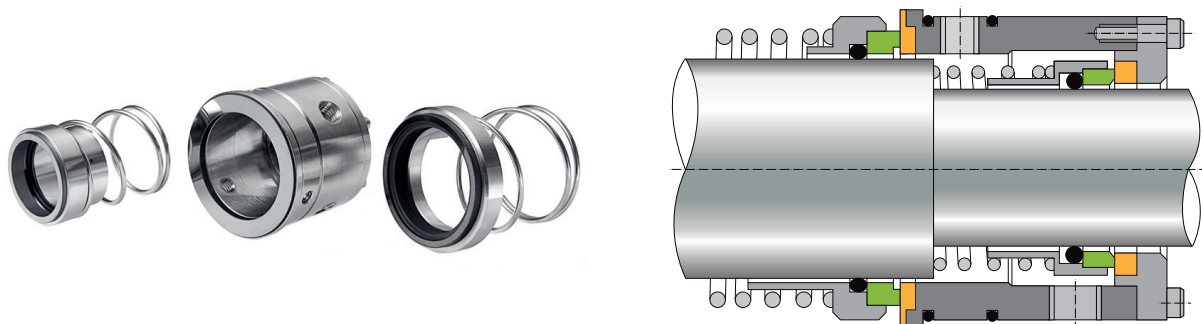

BOMBAS ALFA LAVAL

TIPO 75 Ø 1"

Cierre mecánico para Bomba TZ1

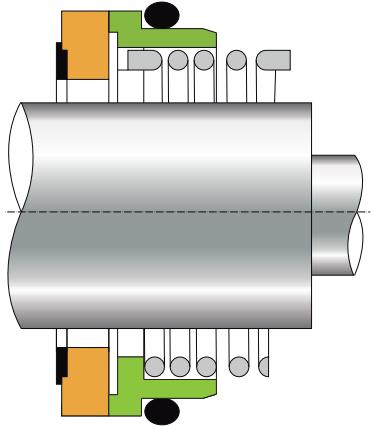

TIPO 77 Ø 42

Cierres mecánicos para Bombas Tipo LKH70 y LKH80

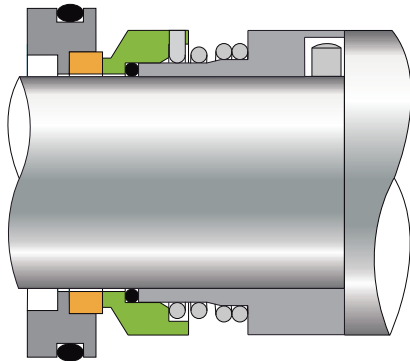

TIPO 79 Ø 22

Cierres mecánicos para Bombas Tipo MR166A, MR166B y MR166E

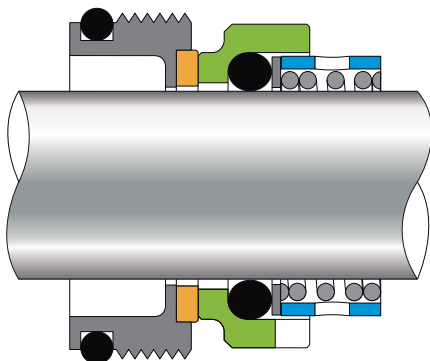

BOMBAS ALFA LAVAL

TIPO 80 Ø 22

Cierres mecánicos para Bombas Tipo ME155AE, GM1, GM1A, GM2 y GM2A



TIPO 81 Ø 20 - Ø 30 - Ø 35 - Ø 45 - Ø 55 - Ø 75

Cierres mecánicos para Bombas de rotor de lóbulo de nueva generación Tipo LKPL, NMOG y SRU.
Cierre HY-clean



TIPO 84 Ø 3/4" - Ø 1 1/8" - Ø 1 1/2"

Cierres mecánicos Para Bombas Triclover

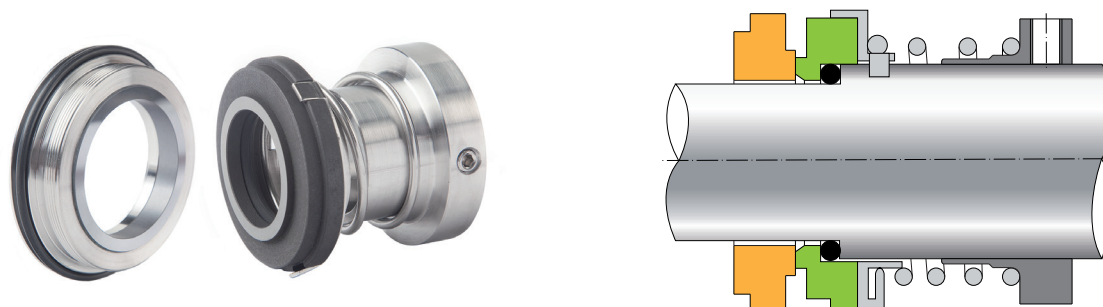

BOMBAS ALFA LAVAL

TIPO 83 Ø 32

Cierres mecánicos para Bombas LKH-110

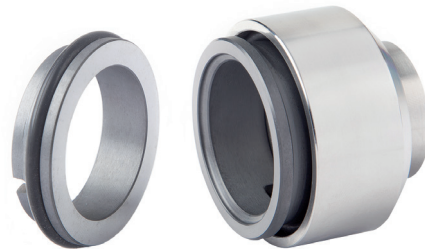
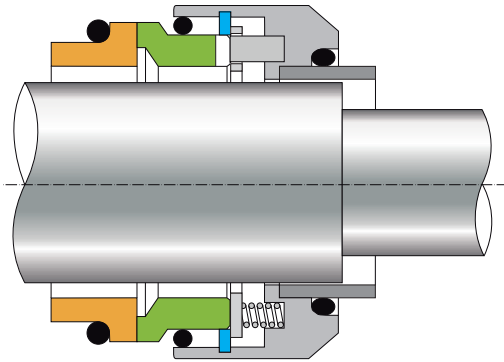

TIPO 85 Ø 32 - Ø 42

Cierres mecánicos para Bombas de múltiples etapas LKHI, LHKP, LKHSP y LKH100

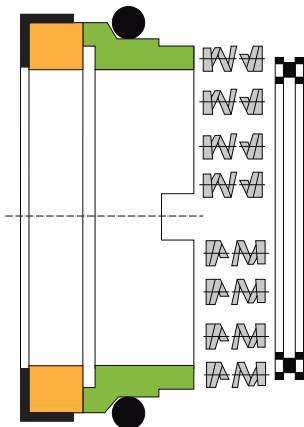

TIPO 92 Ø 35

Cierres mecánicos para Bombas Alfa Laval SSR

